

ABS-Lock®Falz H

PF-H

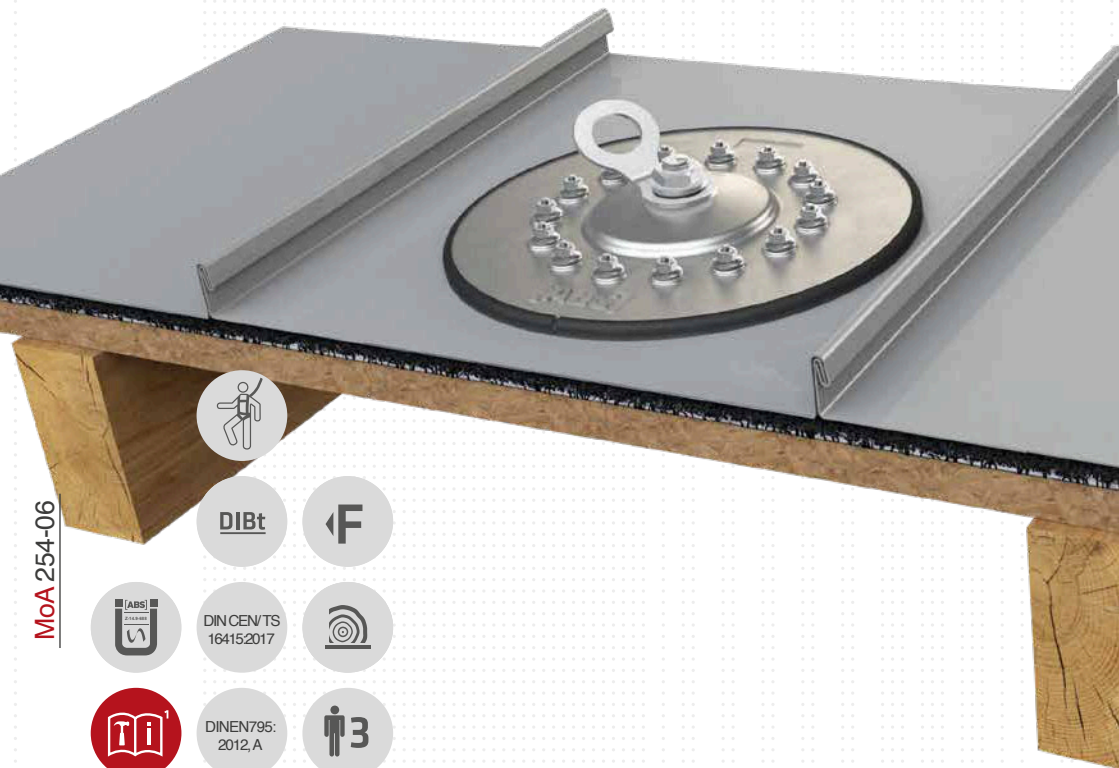

MoA 254-06



DIBt



DIN EN TS
16415:2017



DIN EN 795:
2012, A



Werkzeuge | Tools

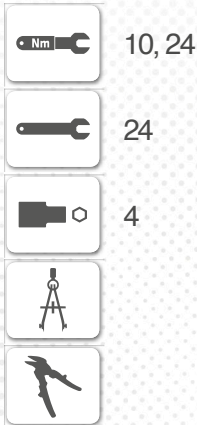

Sicherheitshinweise | Safety instructions



- DE** DieAnweisungenderMontageanleitung(1) undSicherheitshinweise(2) sindstrikteinzuhalten.
- EN** Theinformationcontainedintheassemblyinstructions(1) andsafetyinstructions(2) mustbestrictlyobserved.
- NL** Deaanwijzingenin demontagehandleiding(1) enveiligheidsvoorschriften (2) moetenstrikto wordennageleefd.
- ES** Respeitelectricamente lasinstruccionesdel manual demontaje(1) y lasindicacionesdeseguridad (2).
- IT** Èassolutamentenecessarioattenersi alleistruzioni di montaggio(1) e allenormedi sicurezza(2).
- FR** Lesinstructionsdelanoticedemontage(1) et lesconsignesdesécurité(2) doivent êtreformellement respectées.
- PL** Należyścisłoprzestrzegaćinstrukcji montażu(1) i wskazańekbezpieczeństwa(2).
- DK** Montagevejledningens(1) anvisninger somogsåskerhedshinvisningene(2) skal overholdes.
- CZ** Jenutřnístřechodržovat instrukceobsaženév montážnímávodu(1) av bezpečnostníchpokynech(2).
- GR** Πρέπει να τηρούνται αυστηρά οι οδηγίες του χειριριδίου συναρμολόγησης (1) και των υποδείξεων ασφαλείας (2).
- SK** Dôslednôdôzvávaťpokyny montážnehoávodu(1) a bezpečnostnépokyny (2).
- TR** Montajklavuzunun(1) veđüvenlik uyarılarınıtamamlatmalı(2) kesinlikleuyulmalıdır.
- NO** Datersvevirkelige instruksjonenei monteringshåndboken(1) ogsikkerhetshetlet (2) følges.
- RUS** Необходимо строго соблюдать требования руководства по монтажу (1) и инструкции по безопасности (2).
- RO** Indicatiiledin instrucțiuniledemontare(1) și din broșuracu indicații desigurantă(2) trebuie respectate cu strictețe.
- FI** Asennusohjeen(1) jaturvaohjevikohosen (2) ohjeitaon ehdottomasti noudatettava.
- SE** Anvisningarnaill monteringsanvisningen(1) ochsäkerhetsmanualen(2) måsteaktasunder allomständigheter.
- H** इस्तेमाल के नक्शे(1) और सुरक्षासूचक(2) मानेसूचक(2)केसही रूपसेगान कर्म जससकती
- ZH** 必须严格遵守装配说明书 (1) 和安全须知单 (2) 中的指示。
- SQ** Jip thezëmbëqësimat dorazemti qe duhet te ndiqen (1) dhe rregullat e sigurisë (2) me shtrëngësi.

Kontakte | Contact persons

Vertrieb & Technische Beratung
Sales & Technical Support
+49 (0) 2832-97281-0
vertrieb@absturzsicherung.de

Schulung
Training

+49 (0) 2832-97281-0
schulung@absturzsicherung.de

Montagevorbereitung
Assembly

+49 (0) 2832-97281-260
service@absturzsicherung.de

Mustertypenschild | Sample label

[ABS]

ABS SAFETY GMBH ³

Kavelaar, Germany
info@absturzsicherung.de
www.absturzsicherung.de

¹
²

Mustertypenschild /
Sample only

Chargennummer /
Batch number

⁶ Normen/ Standards -

⁷ Max. Nutzer gleichzeitig (DIN EN 795:2012)
Max. No. of simultaneous users -

¹¹ Modellnummer / Model number -

-

-

-

⁸

⁹

¹⁰



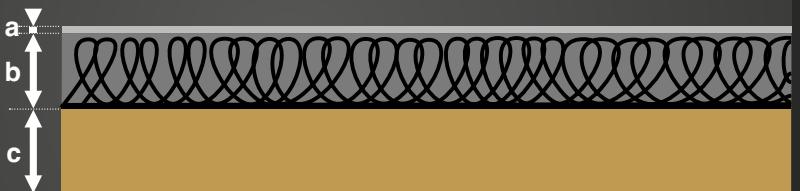
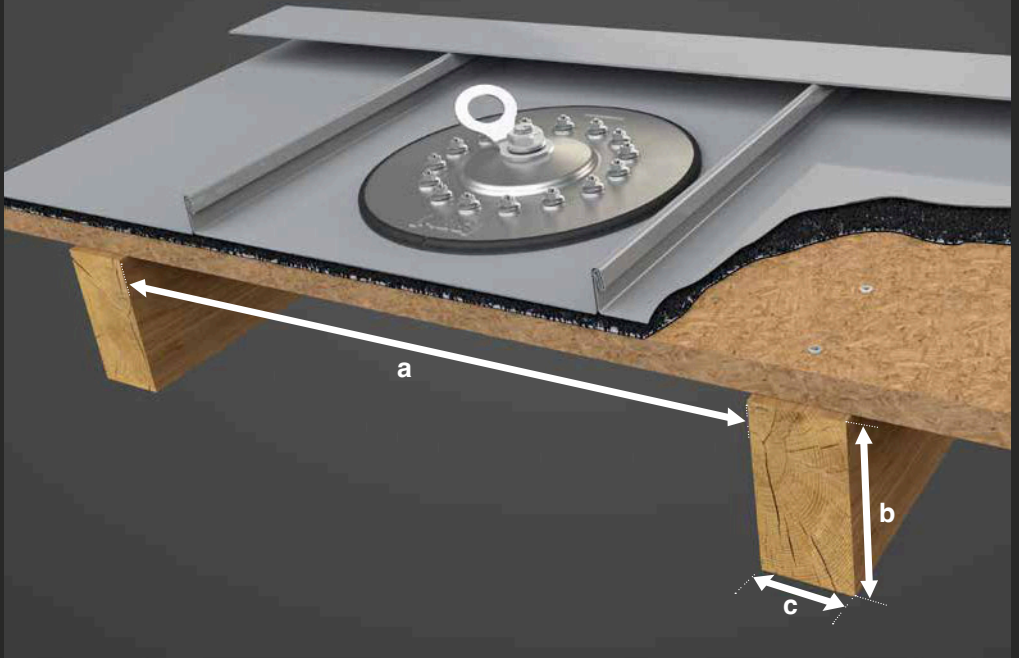

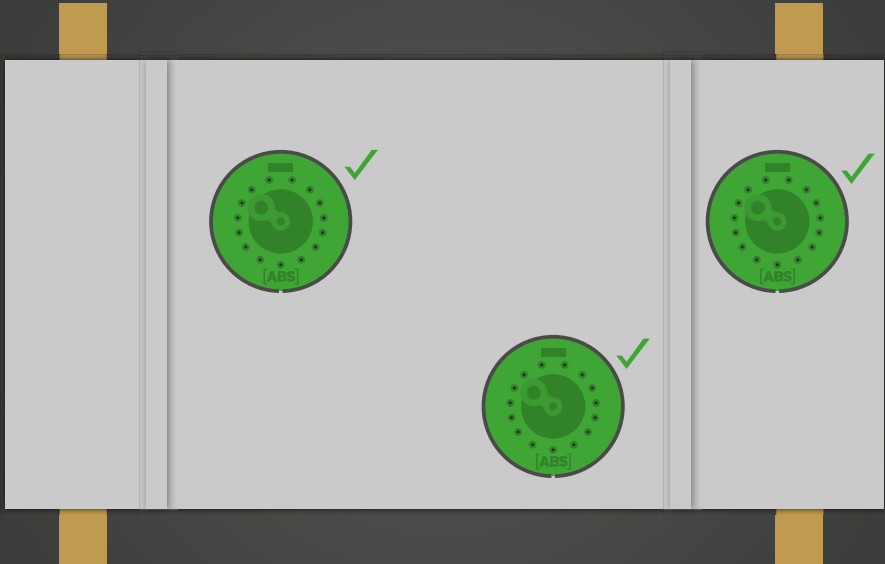
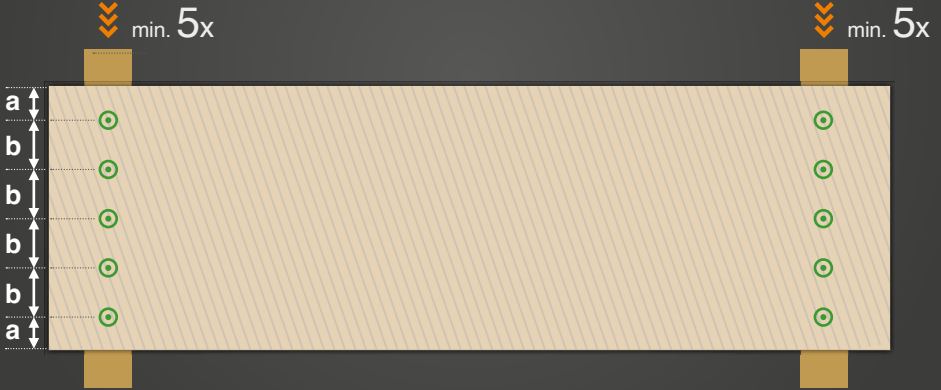



a ↔ 500-1000
mm

b ↔ min. 120
mm

c ↔ min. 60
mm



a ↔ max. 1
mm

b ↔ max. 10
mm

c ↔ min. 24
mm

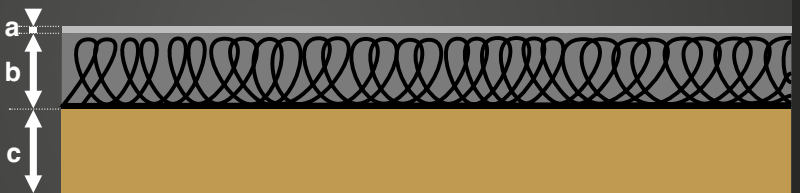

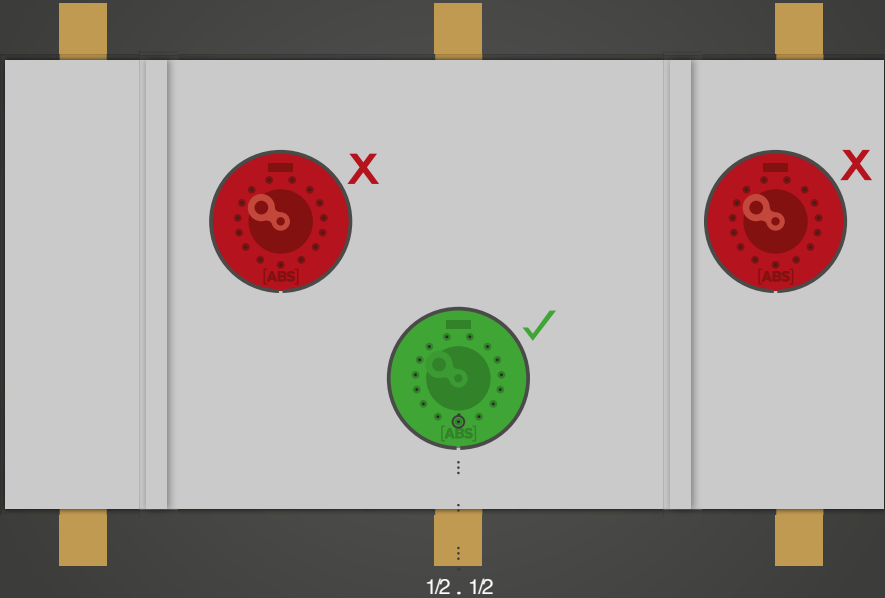
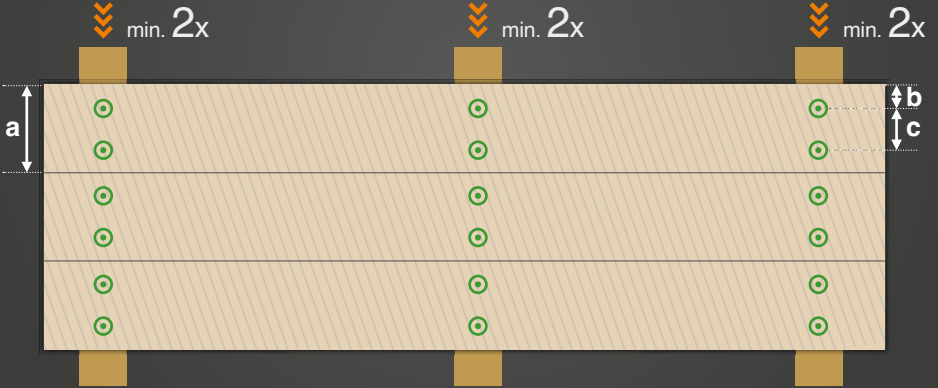

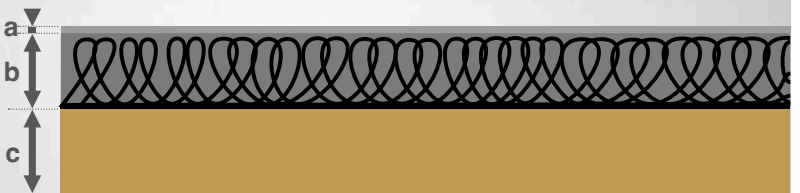
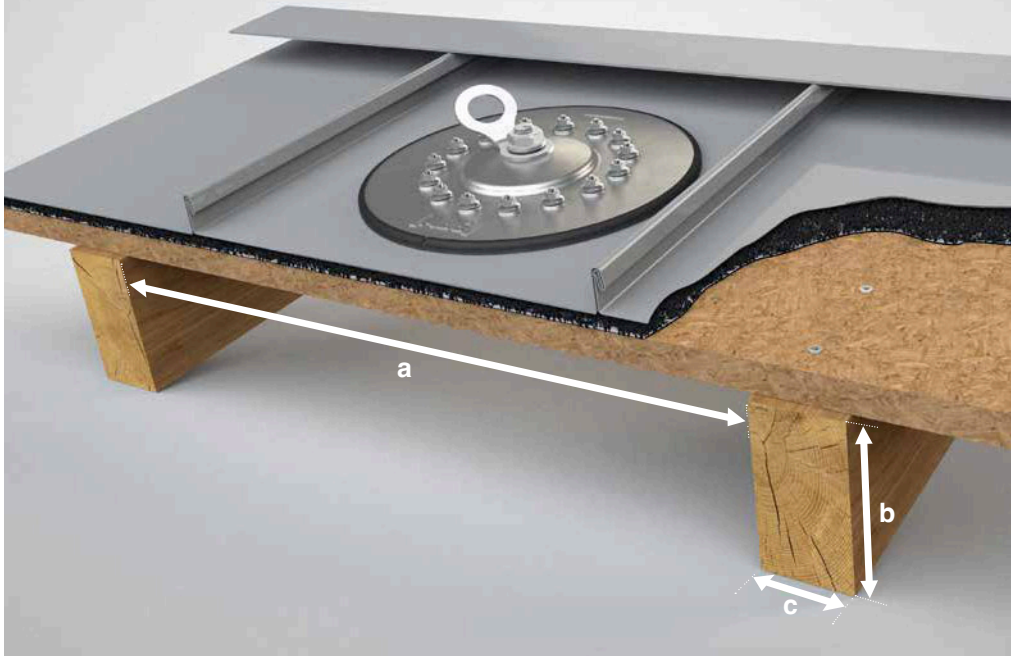



a \longleftrightarrow 500-1000
mm

b \longleftrightarrow min. 120
mm

c \longleftrightarrow min. 60
mm



a \longleftrightarrow max. 1
mm

b \longleftrightarrow max. 10
mm

c \longleftrightarrow min. 24
mm

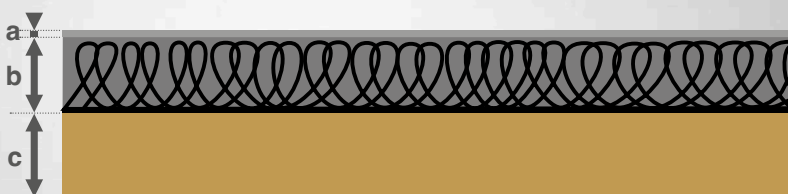

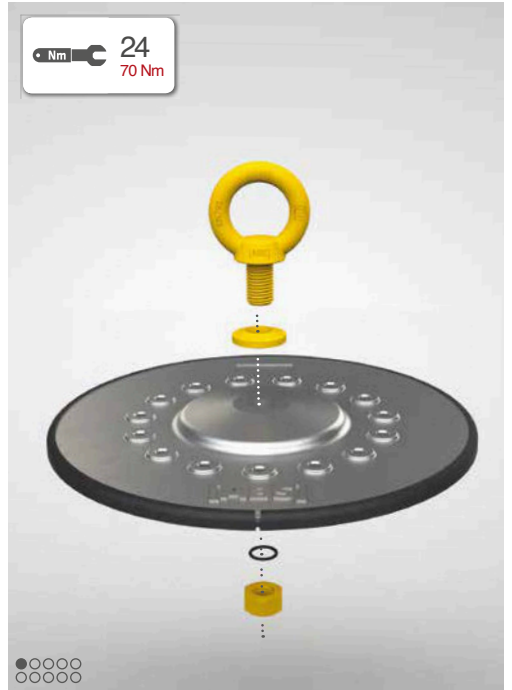
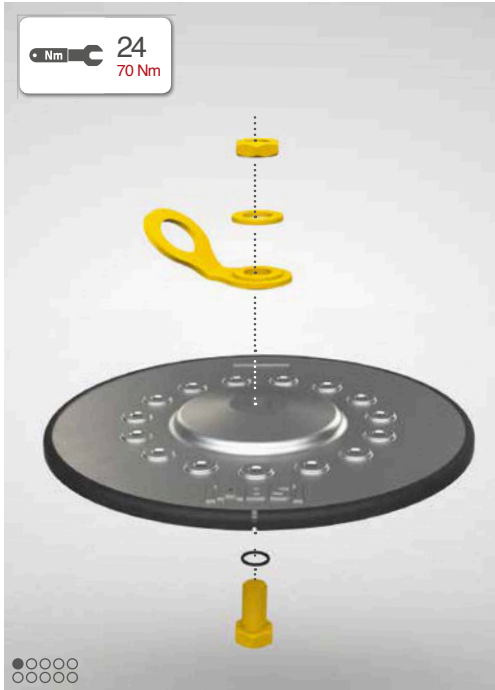

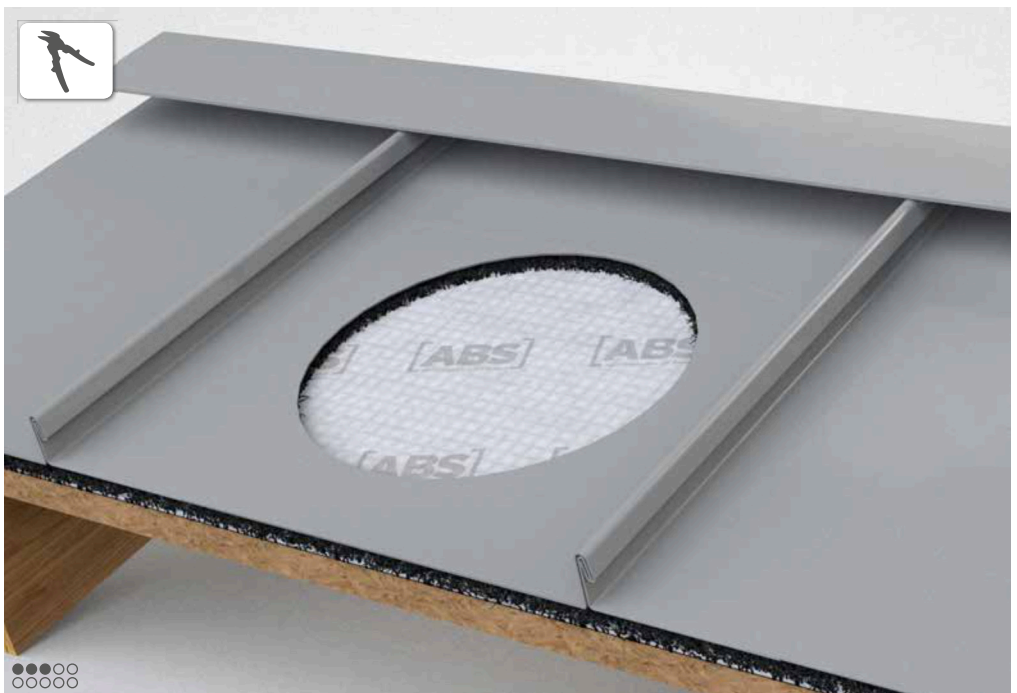
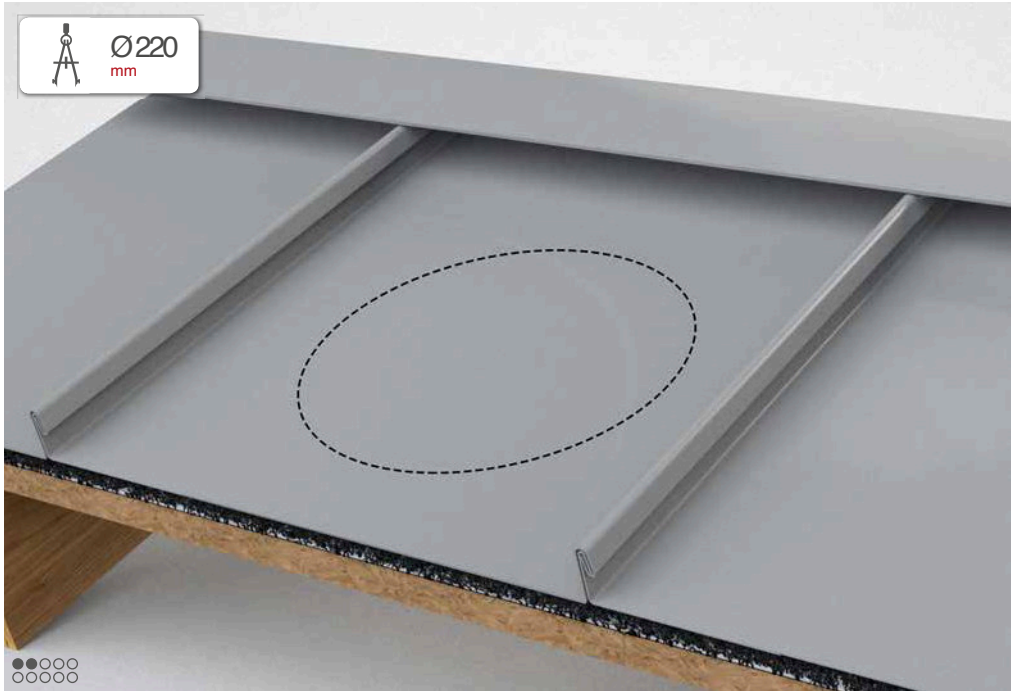

Optional

EPDM-Distanzscheiben zur Überbrückung der Trennlage
EPDM spacer-discs for bridging this separation layer

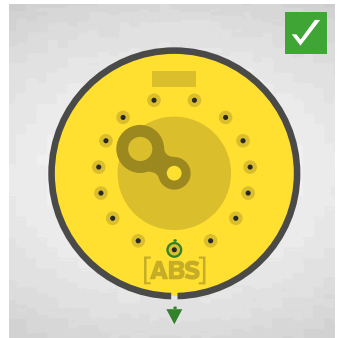
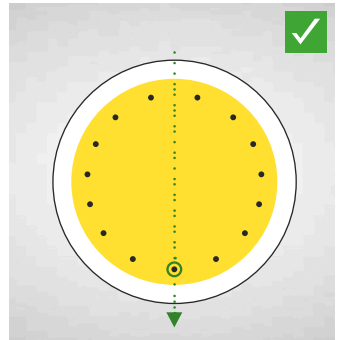
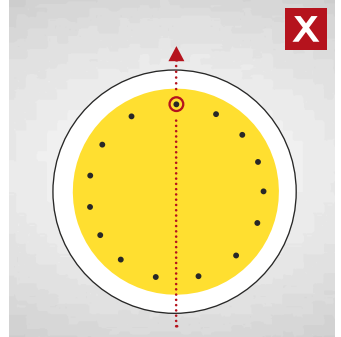
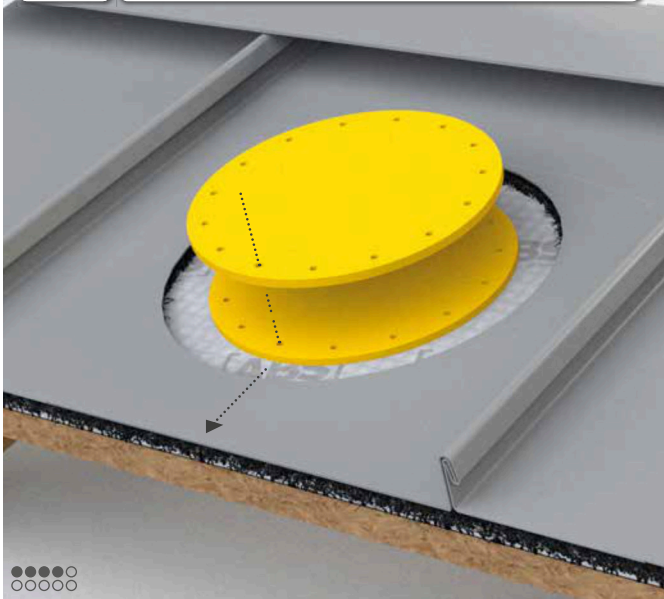

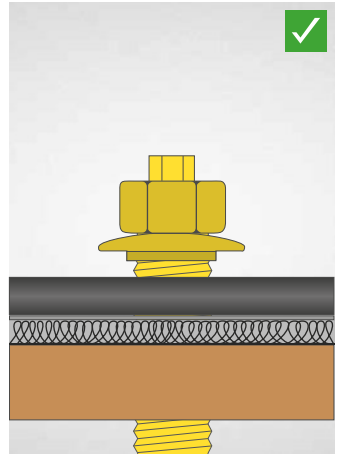
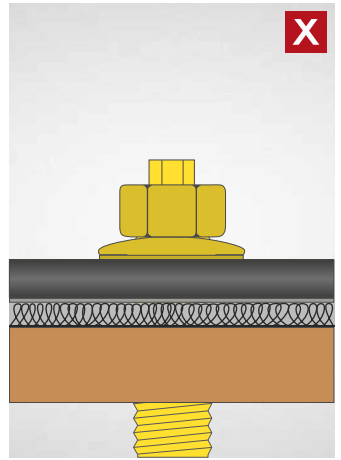
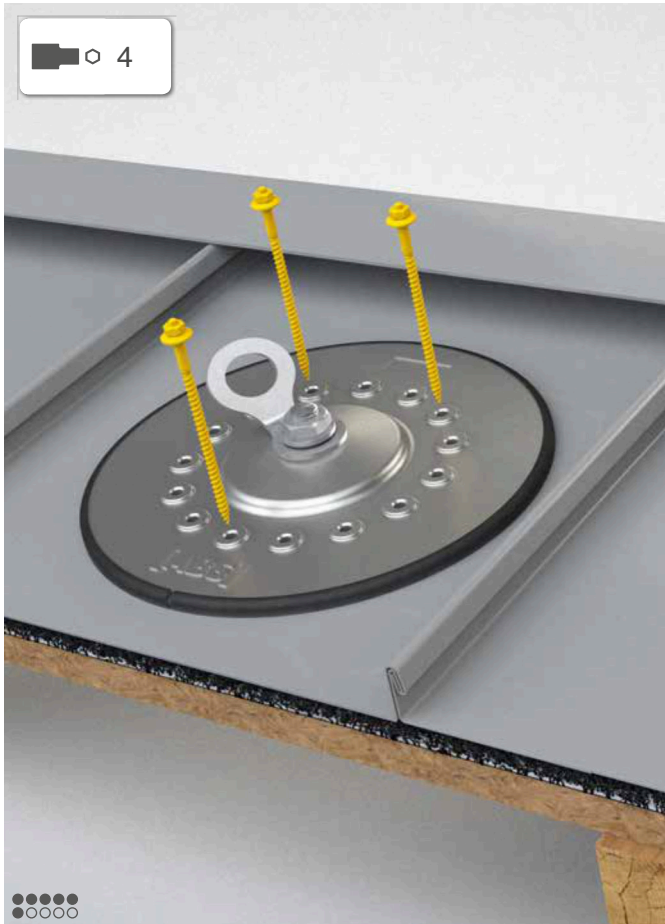

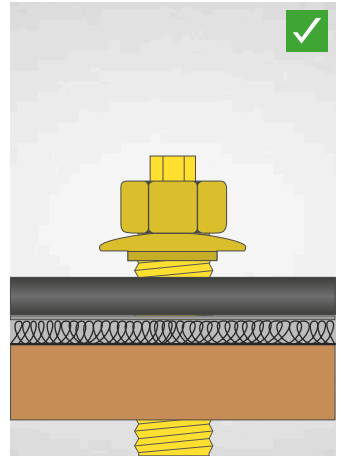
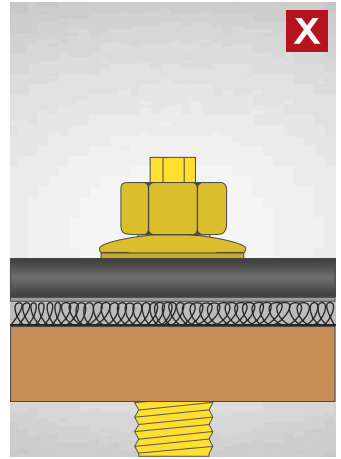
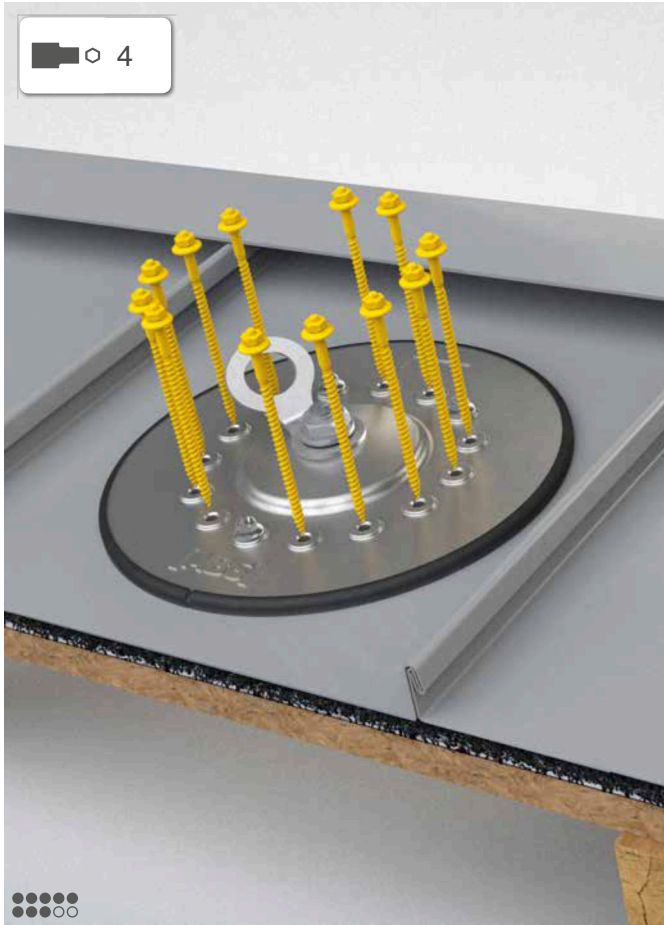

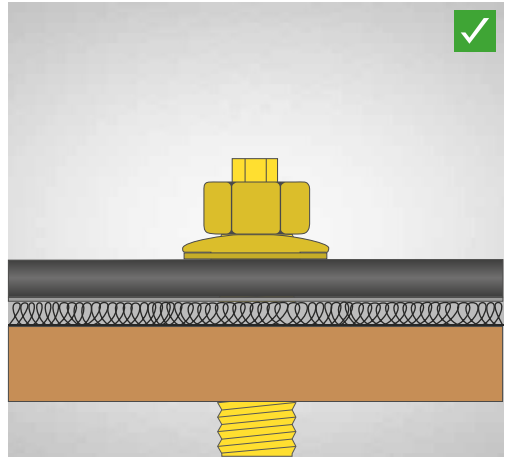
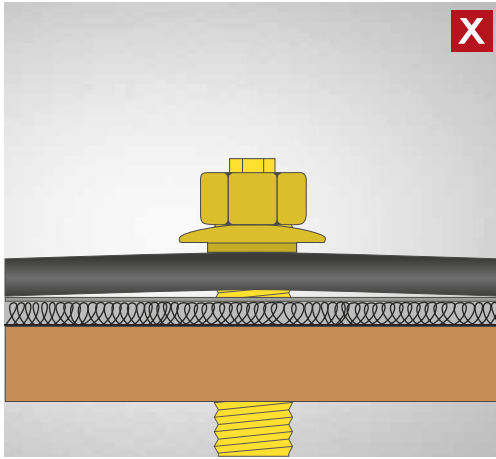

ALWAYS ON TOP!

ABSSafety GmbH

Gewerbering 3
D-47623 Kevelaer
Germany

Tel.: +49 (0) 28 32- 97281- 0
Fax: +49 (0) 28 32- 97281- 29

info@absturzschutz.de

www.absturzschutz.de
www.protection-anti-chute.fr
www.fall-arrest.eu

FS 14, Oktober 2019



[instagram.com/abssafety](https://www.instagram.com/abssafety)



[youtube.com/abssafetygmbh](https://www.youtube.com/abssafetygmbh)



[facebook.com/ABS.Safety](https://www.facebook.com/ABS.Safety)